

HDPE Flap Valves

- DN100-600

- The Flexseal range of Flap Valves fit pipes from DN100 to DN600.
- Mostly HDPE design - hinges and weights are steel over-moulded with HDPE for protection against the environment.
- HDPE material combines strength and lightweight for ultimate reliability and installation convenience.
- Integrated EPDM sealing sections enable the product to be supplied as one part.
- Manufactured to the highest class 5 standard of DIN 19569-4.

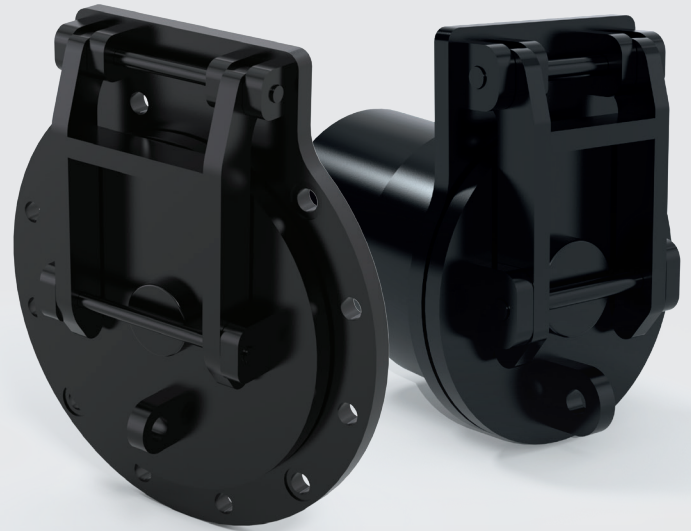

Fernco in conjunction with Flexseal have designed and developed a range of high quality Flap Valves made from HDPE (High Density Polyethylene). The Flap Valve acts as a Non-Return Valve for the prevention of backflow associated with rivers, estuaries, seawater outfalls etc. The lightweight product is easy to install and corrosion resistant.

Flap Valve Standard Range

Wall/Flange Mounted	Spigot Mounted	Application
FV100	FVS100	DN100 pipe
FV150	FVS150	DN150 pipe
FV200	FVS200	DN200 pipe
FV250	FVS250	DN250 pipe
FV300	FVS300	DN300 pipe
FV350	FVS350	DN350 pipe
FV400	FVS400	DN400 pipe
FV450	FVS450	DN450 pipe
FV500	FVS500	DN500 pipe
FV600	FVS600	DN600 pipe



FV150

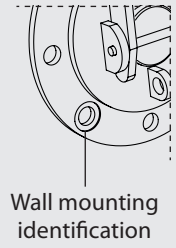
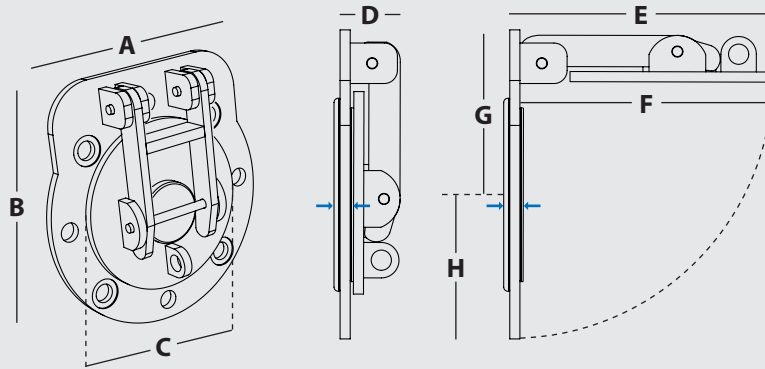

Wall mounting identification

← EPDM Seal

FV100

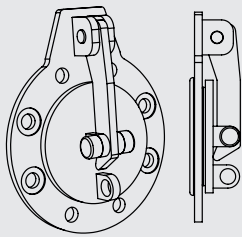

FV200

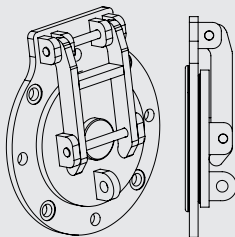

FV250

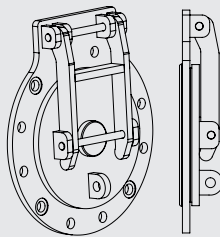

FV300

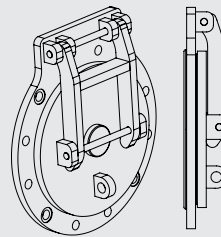

FV350

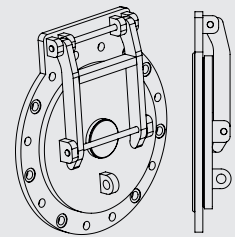

FV400

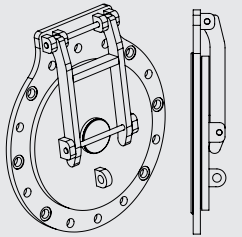

FV450

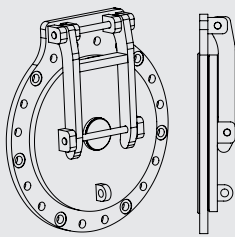

FV500

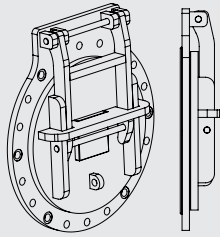

FV600

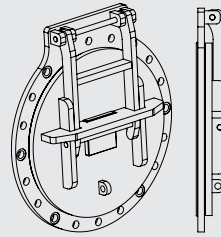

Product Code	DN	Mounting Set	Bolts (qty)	Chemical Anchor Capsules (qty)	A (mm)	B (mm)	C (mm)	D (mm)	E (mm)	F (mm)	G (mm)	H (mm)	Pressure (mwc)	Weight (Kg)
FV100	100	WMK-01	4	4	220	270	145	59	229	219	160	110	5	0.75
FV150	150	WMK-01	4	4	285	305	200	59	262	252	163	142	5	1.1
FV200	200	WMK-01	4	4	340	380	236	74	330	315	210	170	5	2.3
FV250	250	WMK-01	4	4	395	450	285	74	397	382	253	198	5	2.9
FV300	300	WMK-01	4	4	445	496	350	89	455	435	273	223	5	4.8
FV350	350	WMK-02	6	6	505	558	387	89	505	485	305	253	5	5.2
FV400	400	WMK-02	6	6	565	628	431	89	567	547	345	283	5	6.9
FV450	450	WMK-02	6	6	615	673	480	109	625	600	365	308	5	10.2
FV500	500	WMK-02	6	6	670	745	533	109	697	672	410	335	5	14
FV600	600	WMK-02	6	6	780	850	655	109	808	783	460	390	5	17.6

Flexseal Flap Valves are intended for end-of-pipe installation and can be mounted...

- On a vertical or inclined wall (mounting set available)
- On a standard ISO PN 10 pipe flange

Mounting Set includes...

- M8 capsules & fixings for DN100-300 sizes
- M12 capsules & fixings for DN350 sizes and larger
- Chemical resin capsules
- Stainless Steel 1.4401 (316) anchor fixings

WMK-01





FVS150

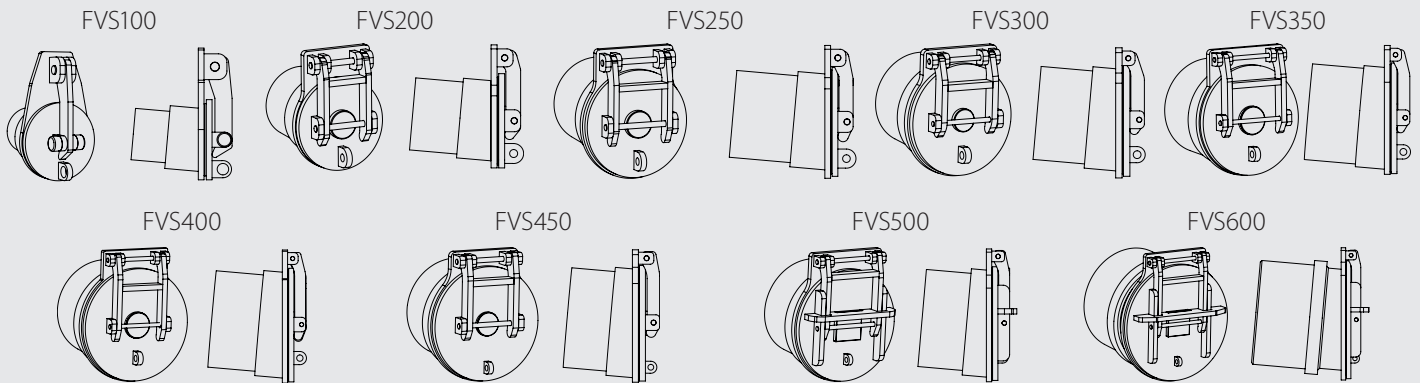
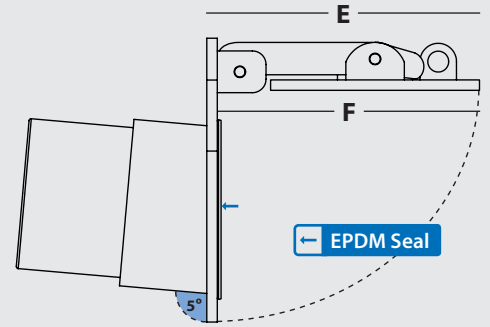
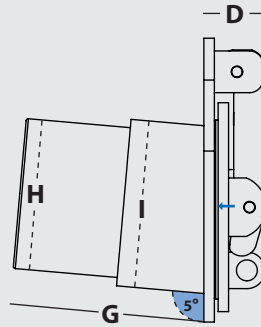
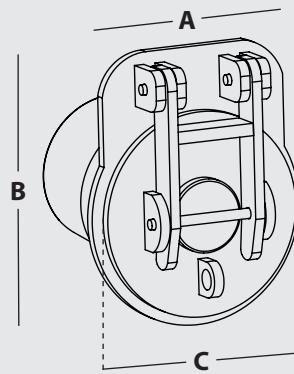

Product Code	DN	A (mm)	B (mm)	C (mm)	D (mm)	E (mm)	F (mm)	G (mm)	H (mm)	I (mm)	Pressure (mwc)	Weight (Kg)
FVS100	100	140	230	140	59	226.5	216.5	109	90	110	5	0.82
FVS150	150	220	272	200	59	261	251	184	144	160	5	1.8
FVS200	200	236	308	236	74	310	295	205	181	200	5	3.3
FVS250	250	295	348	285	74	344	329	252	228	250	5	4.8
FVS300	300	360	403	350	89	405	385	258	289	315	5	8.2
FVS350	350	392	451	387	89	455	435	282	336	355	5	8.7
FVS400	400	440	505	431	89	507	487	285	367	400	5	13
FVS450	450	490	550	480	113	569	544	290	415	450	5	17.7
FVS500	500	545	623	533	109	637	612	324	457	500	5	24
FVS600	600	670	735	655	109	740	715	500	579	630	5	30

All spigot mounted Flap Valves are supplied with a self adhesive strip of EPDM, pre-cut to the correct size. The EPDM strip should be applied to the Flap Valve spigot to create a seal against the internal surface of the host pipe.

Connect with a Standard Coupling to strengthen the installation:

- EPDM rubber conforming to BS EN 681:1
- Stainless steel shear band for extra reassurance
- Permanently maintains water tight seal
- Couplings conform to BS EN 295:4
- Bush may be required depending on outside diameter of main pipe



HDPE Benefits

- Lighter weight than traditional cast iron flap valves, leading to easier installation and lower installation costs
- High strength HDPE will withstand being struck by rocks and other debris, present in marine and river environments, which could shatter lighter weight plastics
- Completely waterproof and maintenance free material
- Not at risk from theft as no inherent scrap value
- Stainless steel hinges and structural steel weights require no maintenance as they have a HDPE covering
- All models (DN100-DN600) can withstand a constant pressure of 5 mwc as standard
- 25 year minimum life expectancy
- Manufactured to DIN 19569-4
- Our flap valves are supplied in accordance with ISO 9001:2015 requirements

Cracking Head

Nominal Diameter	Opening Pressure (Cracking Head) Above Water* (mm)	Inclination (°)		
			Opening Pressure (Cracking Head) Above Water* (mm)	Inclination (°)
100	5	0	30	5
150	8	0	57.5	5
200	9	0	62.5	5
250	10	0	67.5	5
300	12.5	0	84	5
350	15	0	91	5
400	17.5	0	97.5	5
450	18.5	0	106	5
500	20	0	115	5
600	25	0	135	5

*These values do not take into account any disturbing external factors such as currents, swirls or bulky debris.

Product Characteristics

Wall-mount Identification & HDPE over-mould on all Steel items



Fully integrated EPDM 681 seal

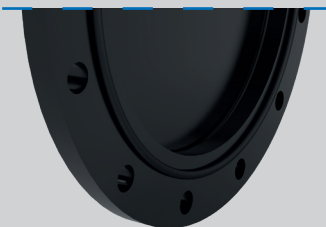

Product Specification for Flap Valve

Product Code(s)	FVXXX or FVSXXX
Description	Wall/Flange Mounted Flap Valves or Spigot Flap Valves
Size Range	From DN100 to DN600
Materials	HDPE Backplate and Flap EPDM integrated seal (meeting requirements of BS EN 681-1) Stainless Steel (304) hinge and structural steel weight encased in HDPE
Standards	Flexseal Flap Valves satisfy the requirements of EN681-1, DIN19569-4, ISO 9001:2015
ISO PN 10	Wall/Flange Mounted Flap Valve

Installation

Installation Guide - Spigot Mounted Flap Valve using Flexible Coupling

1. Ensure pipe end is perpendicular to the pipe body.
2. Clean away any debris from the internal surface of the pipe.
3. Slide coupling onto the pipe.
4. Depending on application a bush may be required to increase the outside diameter of the Flap Valve pipe stop. At this stage place the supplied bush onto the pipe stop.
5. Insert the spigot section of the Flap Valve into the pipe until the pipe end is flush with the Flap Valves pipe stop or bush if used. When inserting ensure the Flap Valve lid hinge is at 12 o'clock.
6. Slide the coupling back over the pipe stop/bush.
7. Tighten coupling evenly down to the pipe and Flap Valve to the correct torque as indicated on the coupling label.

1-2



3



4

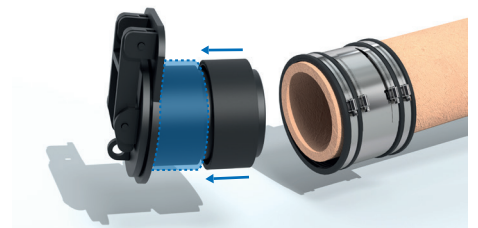

5

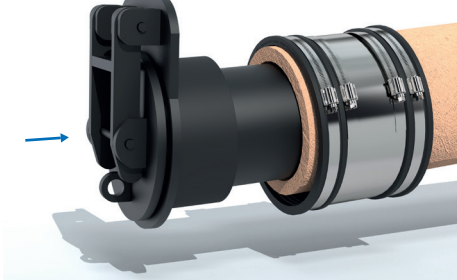

6

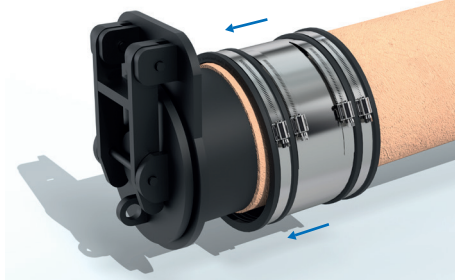

7

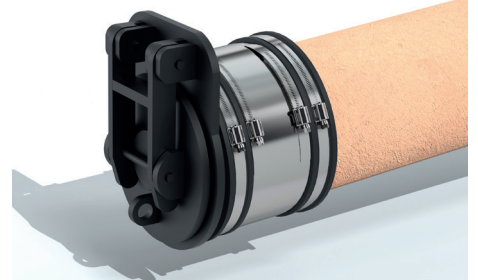

Close Up



Installation Guide - Spigot Mounted Flap Valve using EPDM Wrap

1. Ensure pipe end is perpendicular to the pipe body.
2. Clean away any debris from the internal surface of the pipe.
3. Take the EPDM wrap, supplied with the Flap Valve, peel away the self-adhesive backing from the EPDM sponge and wrap around the external surface of the Flap Valve spigot.
4. Ensure the outside diameter of the wrap is now approx 5mm larger than the internal diameter of the pipe to ensure a compressive fit.
5. Insert the spigot section of the Flap Valve into the pipe until the pipe end is flush with the Flap Valves pipe stop. When inserting ensure the Flap Valve lid hinge is at 12 o'clock.

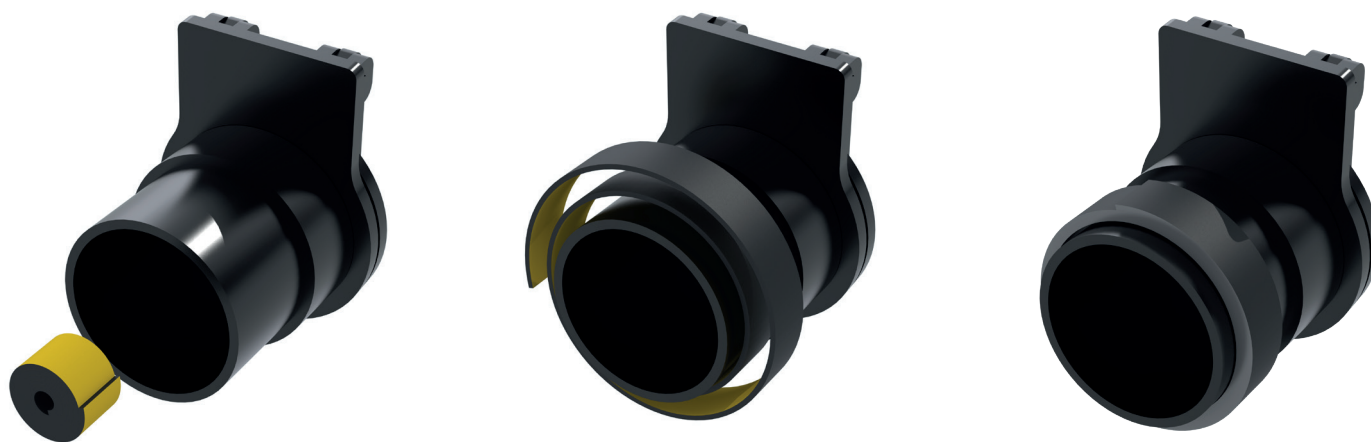

EPDM Wrap Sizing

Flap Valve	Product Code	Spigot OD (mm)	EPDM Thickness (mm)	Max Number of Layers	EPDM Cut Length (mm)	Wrap - Pipe ID Range (Pipe Bore mm)
FVS100	FVMS-SS100	90	5	3.5	1359	92 - 125
FVS150	FVMS-SS150	144	5	3.5	2042	146 - 179
FVS200	FVMS-SS200	181	5	3.5	2510	183 - 216
FVS250	FVMS-SS250	228	5	3.5	3104	230 - 263
FVS300	FVMS-SS300	289	5	3.5	3876	291 - 324
FVS350	FVMS-SS350	336	5	3.5	4470	338 - 368
FVS400	FVMS-SS400	367	5	3.5	4862	369 - 402
FVS450	FVMS-SS450	415	5	3.5	5469	417 - 450
FVS500	FVMS-SS500	457	5	3.5	6000	459 - 492
FVS600	FVMS-SS600	579	5	3.5	7543	581 - 614

Installation Guide - Flange Mounted Flap Valve

1. Offer the Flap Valve to the pipe flange (PN10 as standard), ensuring the lid hinge is at 12 o'clock.
2. Insert all bolts around the full peripheral of the flange/Flap Valve.
3. Tighten bolts equally and oppositely, ensure not to tighten each bolt over a maximum of 50Nm.



Installation Guide - Wall Mounted Flap Valve

1. Offer the Flap Valve to the wall in the desired fixing position, ensuring the lid hinge is at 12 o'clock.
2. Mark drill positions where the wall mounting counter bored/ recessed holes are present. If fixing surface is inadequate where recessed holes are positioned then use alternative holes at equal distances.
3. Remove Flap Valve and drill holes where marked using either a 10mm or 14mm drill bit as indicated in the table below. Ensure the hole depth is consistent with the requirements indicated in the table below.
4. Clean debris away from the drill holes and wall surface.
5. Insert chemical capsules into the hole.
6. Using a hammer drill, drill the bolts provided into the holes and chemical capsules, until the depth of the hole has been reached. Excess capsule residue may disperse from the hole so use care when inserting the bolts.
7. Leave the chemical to cure, time indicated in the table below.
8. Offer the Flap Valve over the bolts, place on the supplied washers and nuts.
9. Tighten to the required torque as indicated in the table below.

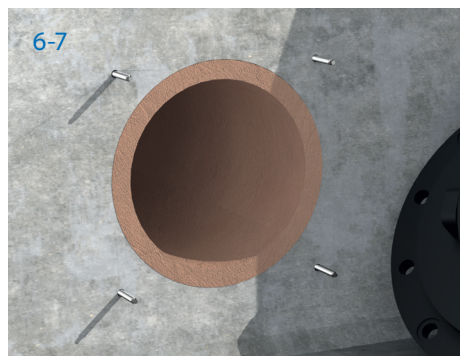
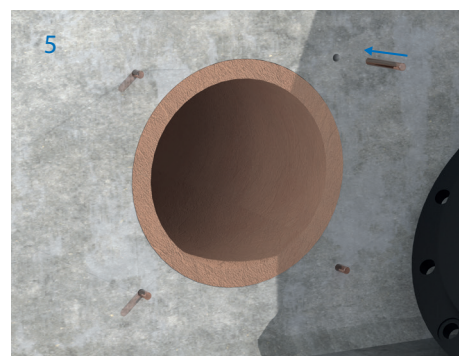
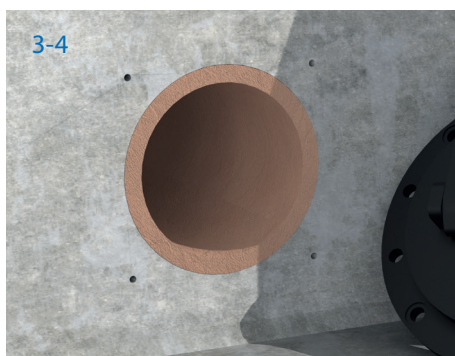

Wall Mounting Kit Installation Requirements

Wall Mounting Kit	Flap Valve Size	Bolts	Drill Bit Required	Drill Depth	Tightening Toque
WMK-01	100-300	M8	10mm	80mm	10Nm
WMK-02	350-600	M12	14mm	110mm	40Nm

Chemical Capsule Cure Time

Temp °C	-15 – -10	-9 – -5	-4 – 0	+1 – +5	+6 – +10	+11 – +20	+21 – +30	+31 – +40
Cure Time	30 h	16 h	10 h	45 min	30 min	20 min	5 min	3 min

General Information

Quality, Standards and Approvals

Certified by the British Standards Institution (BSI) as a company of assessed capability, with a quality management system which meets the requirements of BS EN ISO 9001:2015

Fernco are the leaders in wastewater connection innovation; utilising the most advanced methods and techniques for precision-manufactured products, all of which comply with or exceed relevant British and European standards to ensure reliability and sustainability.

Environment

Operating Environmental Management Systems which are certified to ISO 14001: 2015.

Supply

All Fernco products are supplied through a national and global network of distribution and merchant partners. For stockist details, contact Fernco.

Technical Support

Fernco have a team of product experts on hand to support all customers with technical support and advice.

Contact Flexseal Technical Department:

Tel: +61 (0) 2 9450 0766

Email: technical@fernco.com.au

Enquiries

Sales:

Tel: +61 (0) 2 9450 0766

Email: sales@fernco.com.au

