

## GASMARK APPROVED LUGGED BUTTERFLY VALVE



GASMARK CERT NO. GMK10111



### TECHNICAL SPECIFICATION

**Size:** 50mm - 150mm

**Pressure Rating:** 800kPa

**Flange Drilling:** Table E

**Temperature Range:** 0°C to 60°C

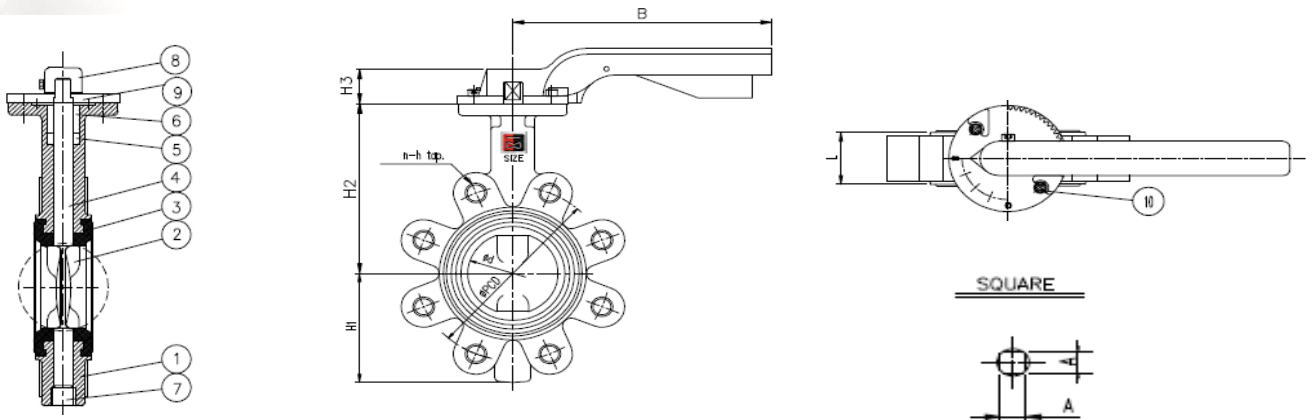

### TECHNICAL : VALVE DETAILS

1	DI body	hammertone
2	Disc	SS CF8M
3	Seat	NBR
4	Stem	SS410
5	Packing	NBR

6	Packing ring	Acetal
7	Plug	plated MS
8	Lever	Aluminium FBE
9	Indicator	Aluminium FBE
10	Bolt/Nut	SS304

### VALVE DIMENSIONS

DN	D	PCD	N	H	L	H1	H2	H3/A
50 (2")	51.5	114	4	M16	43	75	130	37/11X11
65 (2-1/2")	63.5	127	4	M16	46	80	137	37/11X11
80 (3")	78	146	4	M16	46	100	157	48/11X11
100 (4")	101.5	178	8	M16	52	110	171	48/11X11
125 (5")	125	210	8	M16	56	123	184	48/14X14
150 (6")	148	235	8	M20	56	143	203	48/14X14