

Gear Operated HVAC Butterfly Valve

- HVAC, Water, Waste Water Treatment, processing, mining, General Industry, Non-Water Marked Systems
- Operation Pressure 1600kPa
- Temperature Range -10°C to 120°C
- Ductile Cast Iron Body with Peroxide Cured EPDM Seat
- Sizes range from 50mm to 600mm

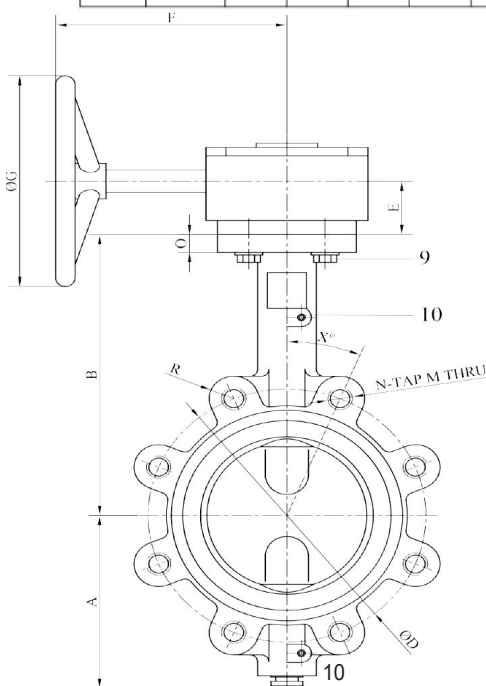

Size		A	B	C	AS2129 TABLE-E				AS2129 TABLE-D				R	E	Ø ₁	Ø ₂	Ø ₃	Ø ₄	L	S	P
mm	inch				ØD	M	N	X°	ØD	M	N	X°									
50	2"	85	162	32	114	M16	4	45	114	M16	4	45	15	11	88	65	50	7	42	9	260
65	2½"	98	174	32	127	M16	4	45	127	M16	4	45	15	11	104	65	50	7	45	9	260
80	3"	104	181	32	146	M16	4	45	146	M16	4	45	15	11	118	65	50	7	45	9	260
100	4"	123	200	32	178	M16	8	22.5	178	M16	4	45	16	12	150	90	70	9.5	52	11	260
125	5"	136	213	32	210	M16	8	22.5	210	M16	8	22.5	18	12	174	90	70	9.5	54	14	260
150	6"	148	225	32	235	M20	8	22.5	235	M16	8	22.5	20	12	206	90	70	9.5	56	14	260
200	8"	186	260	38	292	M20	8	22.5	292	M16	8	22.5	20	13	260	125	102	11.5	60	17	360
250	10"	212	292	38	356	M20	12	15	356	M20	8	22.5	24	14	316	125	102	11.5	66	22	360
300	12"	251	337	38	406	M24	12	15	406	M20	12	15	24	16	370	125	102	11.5	77	22	360



Actuator flange (top flange)

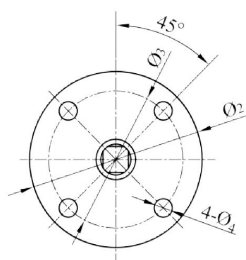

Item	Description	Material
1	Gearbox	
2	Bushing	PTFE
3	O-Ring	EPDM
4	Disc	CF8
5	Seat	EPDM
6	Lower Stem	SS304
7	Body	DI
8	Upper Stem	SS304
9	Bolt	SS304
10	Spring Pin	SS304

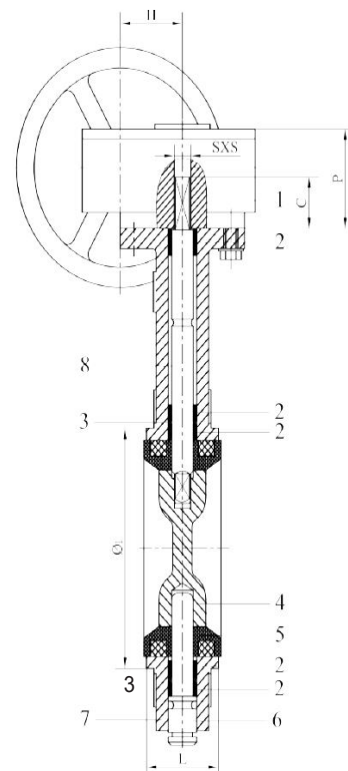

DN	A	B	C	D	E	F	AS 20219 Table E			L
							G	N	Tap M	
350	277	368	80	278	37	225	470	12	M24	77
400	308	400	98	376	52	291	521	12	M24	86
450	342	422	99	376	52	291	584	16	M24	105

Item	Description	Material
1	Gear Operator	
2	Bolt	SS
3	Stem	SS410
4	O Ring	EPDM
5	Seat	EPDM
6	Disc	CF8
7	Body	DI
8	End Cap	DI
9	Bolt	SS
10	Bushing	PTFE
11	Tapper Pin	SS304

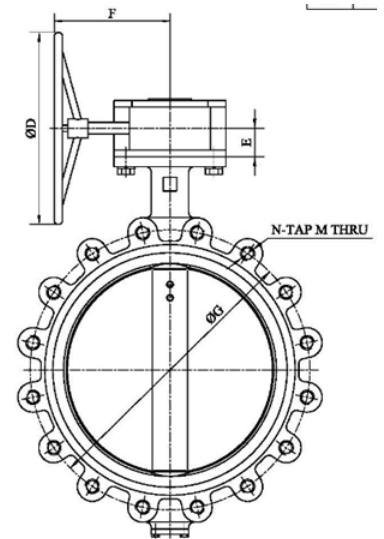
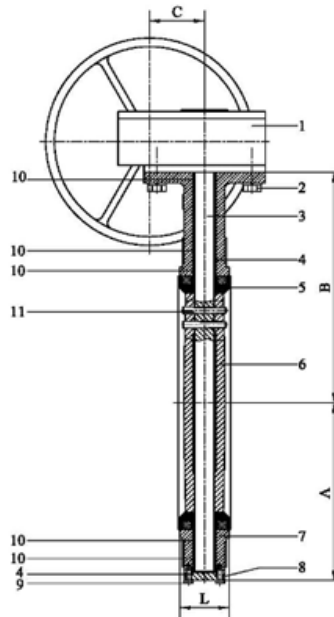

DN	A	B	C	D	E	F	AS 20219 Table E			L
							G	N	Tap M	
500	374	479	170	285	120	252	641	16	M24	130
600	459	562	195	376	135	295	756	16	M30	152

Item	Description	Material
1	Gear Operator	
2	Bolt	SS
3	Stem	SS410
4	O Ring	EPDM
5	Seat	EPDM
6	Disc	CF8
7	Body	DI
8	End Cap	DI
9	Bolt	SS
10	Bushing	PTFE
11	Tapper Pin	SS304

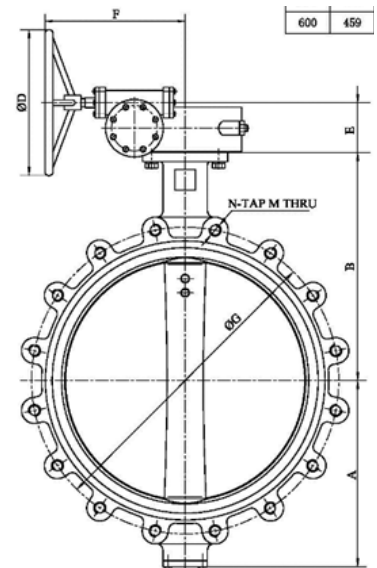
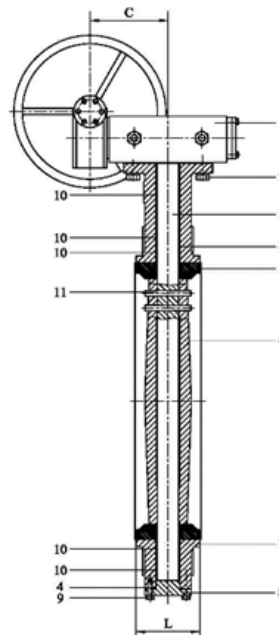

Gear Operated HVAC Butterfly Valve

Storage Conditions

- To protect the seat and seals, do not unpack the valves until they are ready for installation. By doing this you are protecting the valve from dust and debris which may eventually cause seat leakage.
- Keep in a cool well-ventilated space if storing for a longer period.

Valve Installation

- Valves can be installed in any orientation however it is best if it can be installed upright especially in bigger sizes to reduce load on the shaft caused by the actuator or gearbox trying to pull away.
- It is common for smaller butterfly valves to be mounted in various orientations e.g., water trucks. This is fine and is common practice.
- Verify the material of the butterfly valve, seat, and disc before installation. Ensure that there are no defects caused by storage or transportation.
- Verify the pressure rating of the valve vs the application requirement.
- When installing directly to a pump or another valve be sure to have a pipe spacer between them to allow for the butterfly disc to open.
- Complete all welding works before valve installation and be sure the flange has cooled to ambient temperature before installing the butterfly valve.
- Make sure there is no welding residue, waste, rust, or other debris in the pipe before installation. Wash with water or a mild detergent if needed.
- Clean the surface of the flange that will encounter the butterfly valve to ensure it is free of rust and debris. Wash with water or a mild detergent if needed.
- Make sure there is no warpage of the flange or misalignment of the butterfly valve in relation to the flange. This is the most common cause of butterfly valve problems where it is not aligned with the flange/pipe correctly and the disc catches when trying to open/close. Support the valve where necessary to reduce load from the piping assembly.
- Install spacing bolts taking care not to damage the valve seat and adjust the face to face of the two flanges so there is space when the piping is spread open (enough space to remove the valve or replace it for maintenance).
- Once the pipes are centred, insert the bolts so that the bottom of the valve can rest upon them to prevent the valve from falling through.
- Before tightening the bolts operate the valve to ensure it does not catch on the pipework or the flange.
- Tighten the bolts one at a time doing it in stages so even pressure is applied, and a seal is formed between the valve and flanges.
- Once the installation is complete operate the valve several times to ensure it is free from impingement and it has not moved during installation.

Field Testing

- Rubber seated butterfly valves are designed to hold rated pressures only. Test pressures above rated working pressure in the closed position can cause damage to the valve.
- With the disc in the open position the pipeline can be tested up to the valve hydrostatic test pressure.
- Seat leakage can occur with foreign material between the seat and disc. If this occurs open the valve 10 to 15 degrees to obtain high velocity flushing action. Close and repeat if necessary.
- Seat leakage can result from a rotational shift in position of the disc in relation to the body. Readjust the closing stop on the actuator/gearbox as necessary.
- For dry applications actuator stops can be adjusted to stop the disc burying all the way into the seat. This will still allow a bubble tight seal but prolong life span of the seat.

Operation

- Do not use the valve at pressures above its working pressure.
- If the valve is jammed in a position between open and closed check the actuator operation. If necessary, remove the actuator and manually operate the valve to fault find. Remove and check valve for foreign objects if required (see maintenance).
- Excessive torque from the actuator can damage the internal valve parts.

Maintenance

- Cycle the valve once every three months or more if it is not used regularly.
- Relieve the system pressure before maintaining the valve.
- To remove from pipework, reverse the installation sequence.
- Replace valve seat (liner) by removing the stem and disc. Press out liner and replace with new part. Reinstall the disc and stem along with seals and clips. Refit into line as in installation sequence.

Design Guidance & Product Advantages

- When sizing the valve always consider available space for the actuator and feedback devices.
- Consider valve supports to carry excess loads.