

Climate
Control

IMI TA

TA-Therm ZERO



Circulation valves

Thermostatic circulation valve

TA-Therm ZERO

This thermostatic valve for automatic balancing in domestic hot water systems features a step-less temperature setting, saving energy with reduced delay time for hot water. The shut-off function enables straightforward maintenance while the temperature control feature delivers safer operating procedures. The TA-Therm ZERO is a lead-free product (<0.1% lead content) especially designed to address local environmental demands.



Key features

ZERO lead

Product made of lead-free brass (<0.1% lead content).

Thermometer

For easy maintenance.

Technical description

Application:

Domestic hot water systems.

Functions:

Stepless temperature setting
Shut-off
Temperature control

Dimensions:

DN 15-20

Pressure class:

PN 16

Static pressure:

Max. static pressure during temperature control 10 bar.

Temperature:

Max. working temperature: 90°C

Temperature range:

35-80°C (WRAS approved up to 65°C)
Pre-set at 55°C
Kv at pre-set temperature: 0,3

Material:

Valve body: Brass CC768S
Valve plug: Corrosion-resistant acetal plastic
Seat: Corrosion-resistant polysulphone plastic
Other parts in contact with water: Brass CW724R (CuZn21Si3P)
O-rings: EPDM rubber
Handwheel: Glassfibre reinforced polyamide plastic

Marking:

Valve body: TA, ZERO, PN 16, DN, DR, flow direction arrow.
Handwheel: IMI TA and WaterMark logo

Approvals:

WaterMark, IAPMO R&T OCEANA

General

Today, most of the larger buildings have domestic hot water circulating systems in order to reduce the delay time for the water to run hot at the taps.

A TA-Therm thermostatic circulation valve can be fitted instead of a conventional balancing valve.

The valve opens when the temperature of the domestic hot water upstream of the valve is lower than the set temperature and when the supply temperature exceeds the set temperature, the valve closes. The flow of domestic hot water stops until the temperature of the water in the pipe has fallen below the set value, then the valve re-opens and again allows hot water to circulate.

TA-Therm is fitted with a manual shut-off valve in order to allow repair work to be carried out on the system.

Sizing

The flow requirement in a hot water circulation system is determined by the cooling of the water in the distribution pipes. It is desirable to keep this temperature drop under control, and normally it is recommended a temperature drop of 5-10°C from the hot water tank or boiler etc. to the TA-Therm.

In modern buildings, the heat loss from insulated pipes that will carry the circulating hot water can be estimated to about 10 W/m. From this, the necessary flow rate of the circulation pump can be calculated:

$$q = 10 \times \Sigma L \times 0,86 / \Delta T \quad (q \text{ in l/h})$$

The pump head needs to be sufficient to overcome friction and pressure pulse losses in the pipes to the furthest hot water circulation valve and back, to which must be added the pressure drop across the TA-Therm valve itself, check valve, heat exchanger and other components.

NB!

The output temperature from the hot water tank, boiler etc. must be at least 5°C above the temperature setting of the TA-Therm.

$K_v = 0,3$ (K_v at pre-set temperature)

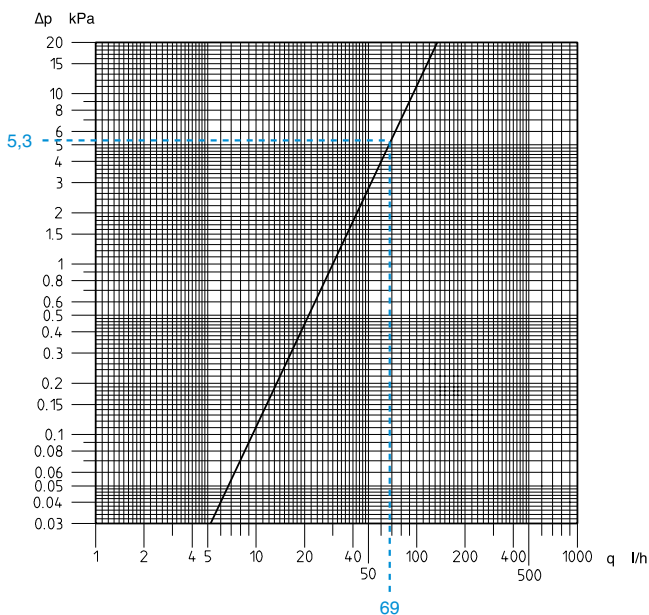

Example

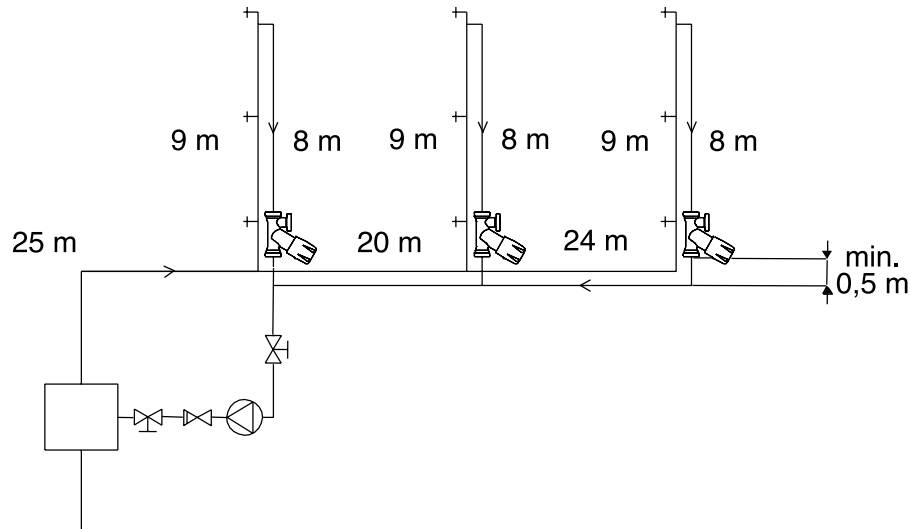

Solution:

Necessary flow to overcome 5°C temperature drop to the last TA-Therm:

$$q = 10 \times (25+9+8+20+9+8+24+9+8) \times 0,86 / 5 = 206 \text{ l/h}$$

Assume that the total flow is divided equally for each TA-Therm. $206/3 = 69 \text{ l/h}$, which gives a pressure drop of 5,3 kPa for DN 15 (see diagram).

The required pump head is then given by:

1. TA-Therm = 5,3 kPa
2. The pressure drop in the hot water pipes to the last tap is estimated to 30 Pa/m (at low load).
 $30 \times (25+20+24+9) = 2300 \text{ Pa} = 2,3 \text{ kPa}$
3. The pressure drop in the hot water circulation pipe (from the last tap and back) is estimated to 100 Pa/m.
 $100 \times (8+24+20+25) = 7700 \text{ Pa} = 7,7 \text{ kPa}$
4. The pressure drop in the check valve, heat exchanger and other components is estimated to 12 kPa.
 $\Sigma \Delta p = 5,3+2,3+7,7+12 = 27,3 \text{ kPa}$

Select a pump to give 206 l/h at a minimum of 28 kPa head.

Installation

TA-Therm is calibrated and pre-set at 55°C.

TA-Therm can be set at any required temperature between 35-80°C.

Installation

(see Diagram B)

Fit TA-Therm in each circulation riser, either at the top or bottom of the riser.

Make sure that the valve is fitted the right way round (an arrow on the valve body indicates the direction of flow) and not closer than 0,5 m from the return pipe.

Temperature setting

(see Diagram A)

- Loosen the locking screw with the 2.5 mm Allen key, and unscrew it until it projects slightly above the handwheel.
- Turn the handwheel anticlockwise to stop.
- Set the required temperature against the casting line along the centre of the valve body (see the dotted line).
- Tighten the locking screw.

Shut-off

(see Diagram A)

- Loosen the locking screw with the 2.5 mm Allen key, and unscrew it until it projects slightly above the handwheel.
- Turn the handwheel clockwise to stop.

Resetting the temperature

(see Diagram A)

- Turn the handwheel anticlockwise to stop.
- Set the required temperature against the casting line along the centre of the valve body (see the dotted line).
- Tighten the locking screw.

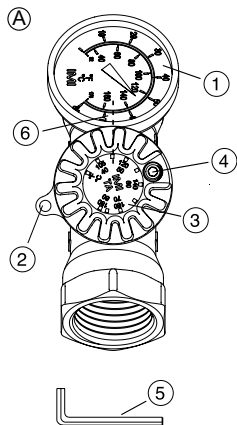

Diagram A

1. Temperature gauge
2. Lug for identification tab
3. Temperature scale
4. Locking screw
5. Allen key for locking screw (2.5 mm)
6. Casting line

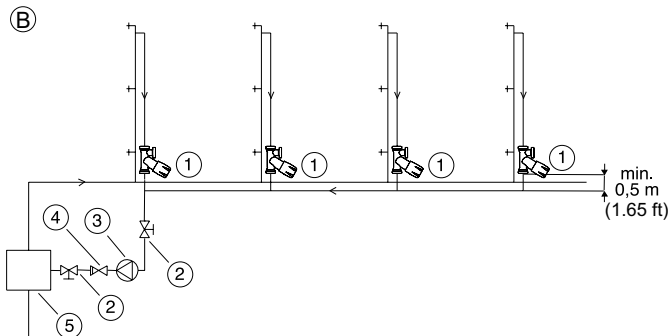
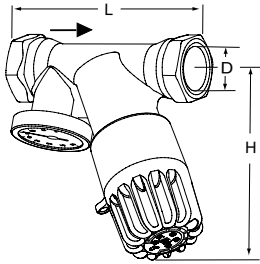

Diagram B

1. TA-Therm
2. Shut-off valve
3. Domestic hot water circulation pump
4. Check valve
5. Heat exchanger

Articles



With thermometer

Pre-set at 55°C

DN	D	L	H*	Kv _{nom}	Kvs	Kg	Article No
15	G1/2	86	90	0,30	1,1	0,45	52 820-915
20	G3/4	92	90	0,30	1,1	0,50	52 820-920

*) Maximum height

TA-Therm is prepared for the compression coupling KOMBI. See catalogue leaflet KOMBI.

Accessories

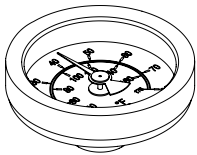

Thermometer
0-100°C

ØD	Article No
41	50 205-003