

TA-BVS 240/243



Balancing valves

Stainless steel, for high media resistance

TA-BVS 240/243

A stainless steel balancing valve that delivers accurate hydronic performance in an impressive range of applications. The TA-BVS is available with flanges or welding ends and is ideal for use mainly on industrial applications and for high temperature.



Key features

- > **Handle**
Equipped with a removable handle that ensures accurate and straightforward balancing.
- > **Measuring points**
For simple, accurate balancing.
- > **Stainless steel**
For high media resistance and longer valve lifetime.

Technical description

Application:

Heating and cooling systems

Functions:

Balancing
Pre-setting
Measuring
Shut-off

Dimensions:

DN 15-250

Pressure class:

Valve body:

DN 15-50: PN 40

DN 65-250: PN 25

Flanges:

DN 15-50: PN 40

DN 65-250: PN 16

(PN 10, 25 and 40 on request)

Temperature:

Max. working temperature: 200°C

Note: Not for steam

Min. working temperature: -30°C

Below -10°C contact IMI Hydronic Engineering.

Media:

Clean media. Also suitable for industrial system with e.g. process water, ethanol, methanol, glycol or freezium.

Material:

Valve body: Stainless steel

EN X2CrNiMo17-12-2 (1.4404).

Ball: Stainless steel EN X2CrNiMo17-12-2 (1.4404).

Spindle: Stainless steel

EN X2CrNiMo17-12-2 (1.4404).

Spindle seals: FPM and NBR.

Ball seal: Hardened PTFE.

Handle:

DN 15-50 stainless steel,

DN 65-150 zinc-plated steel,

DN 200-250 with manual gear.

Measuring points: Stainless steel

EN X2CrNiMo17-12-2 (1.4404).

Marking:

Body and flanges: Traceability No.

Label on body: IMI TA, DN, PN, CE

(according to table), material, max.

temperature, product No and flow

direction arrow.

Marking	PN 40	PN 25
CE 0496*	DN 40-50	DN 65-250

*) Notified body.

Flanges:

EN 1092-1, ISO 7005-1.

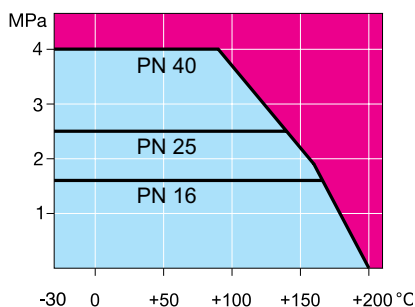

Operating instruction

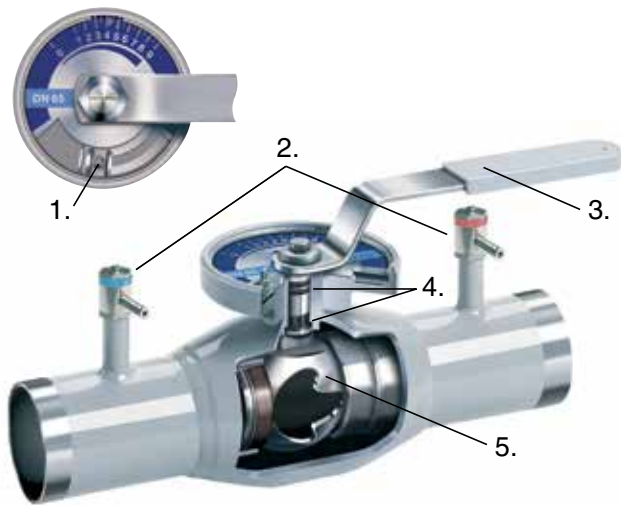

1. Locking screw
2. Measuring points
3. Removable handle
4. Two O-rings. The upper can be replaced during operation.
5. Ball with W-port. Equal percentage valve characteristic.

Measuring accuracy

Deviation of flow at different settings

The curve is valid for valves with normal pipe fittings. Try also to avoid mounting taps and pumps, immediately before the valve.

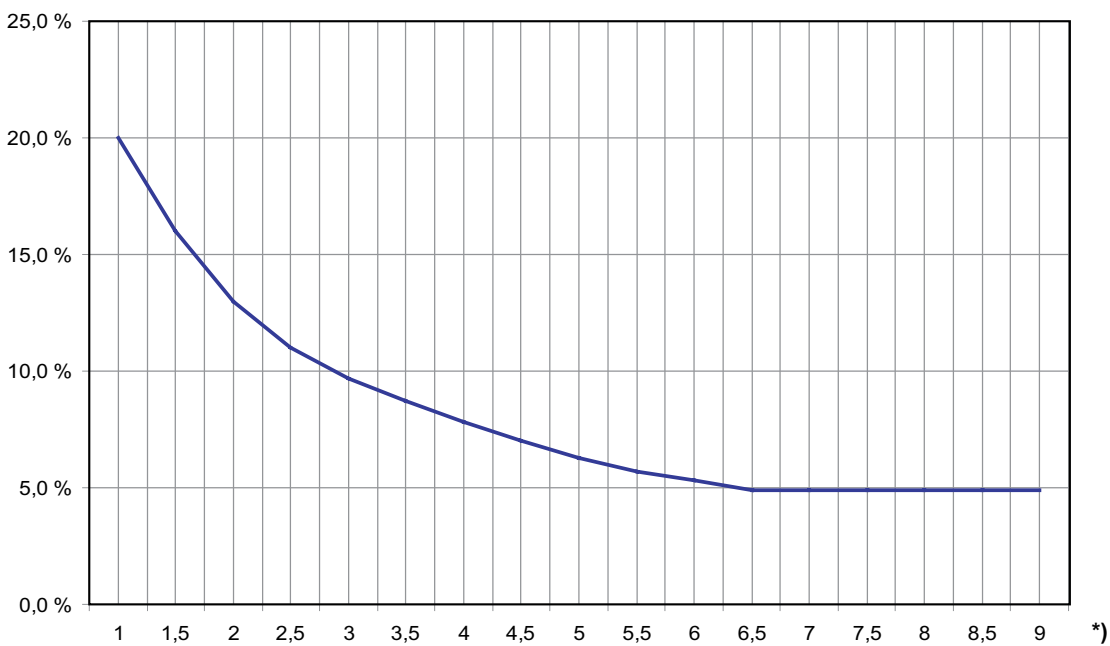

*) Setting.

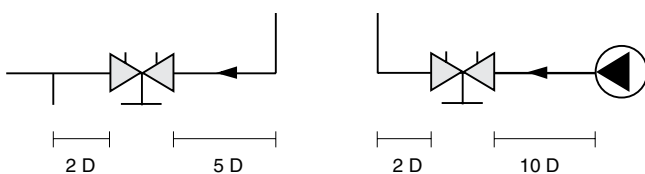

Sizing

When Δp and the design flow are known, use the formula to calculate the Kv value or use the diagram.

$$Kv = 0,01 \frac{q}{\sqrt{\Delta p}} \quad q \text{ l/h, } \Delta p \text{ kPa}$$

$$Kv = 36 \frac{q}{\sqrt{\Delta p}} \quad q \text{ l/s, } \Delta p \text{ kPa}$$

Kv values

Setting	DN											
	15/20	25	32	40	50	65	80	100	125	150	200	250
1	-	-	0,39	0,60	1,26	2,52	3,42	6,48	6,84	13,7	19,7	35,0
1,5	-	0,35	0,57	1,01	1,80	3,64	5,37	9,47	13,3	20,2	20,2	51,2
2	0,14	0,49	0,83	1,48	2,70	4,75	7,31	12,5	18,0	26,6	38,4	66,5
2,5	0,28	0,99	1,08	2,02	3,55	6,34	10,2	16,3	24,3	35,5	51,1	90,0
3	0,42	1,36	1,44	2,70	4,39	7,92	13,1	20,1	30,6	44,3	63,8	110
3,5	0,61	1,66	1,80	3,24	5,61	9,78	16,1	24,5	37,8	55,1	79,3	140
4	0,80	2,00	2,30	3,96	6,84	11,6	19,1	28,8	45,0	65,9	95,0	165
4,5	1,02	2,40	2,74	4,86	8,34	14,2	23,3	35,8	55,3	84,1	121	215
5	1,24	3,00	3,42	5,98	9,83	16,7	27,5	42,8	65,5	102	147	260
5,5	1,64	3,50	4,21	7,18	11,9	20,9	33,2	51,8	81,7	127	183	325
6	2,04	4,50	5,11	8,57	14,0	25,2	38,9	60,8	97,9	152	219	380
6,5	2,64	5,10	5,97	10,2	16,9	29,5	46,3	75,4	122	197	282	500
7	3,24	6,70	7,27	12,3	19,8	33,8	53,6	90,0	146	241	325	576
7,5	3,84	7,30	8,64	14,4	23,4	39,8	64,6	113	177	290	417	740
8	4,45	9,30	10,1	17,6	27,0	45,7	75,6	137	209	338	486	866
8,5	5,04	10,0	11,5	20,9	30,6	53,5	91,8	169	251	400	576	1020
9	5,83	12,6	13,1	22,6	34,2	61,2	108	216	294	461	660	1170

Setting

DN 15-150

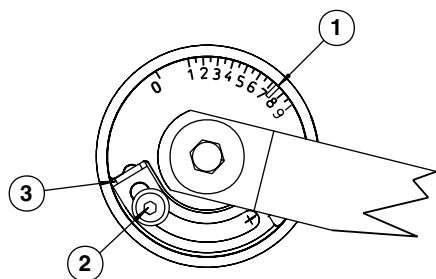

1. Adjust to the desired position **(1)**.
2. Open the locking screw of the limiter **(2)**.
3. Move the limiter against the edge of the scale plate **(3)**.
4. Tighten the locking screw of the limiter **(2)**.

DN 200-250

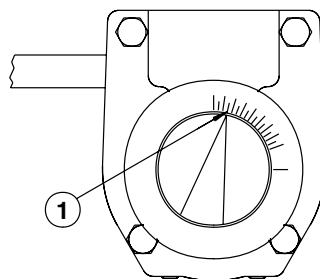

1. Adjust to the desired position **(1)**.

Diagram DN 15-20

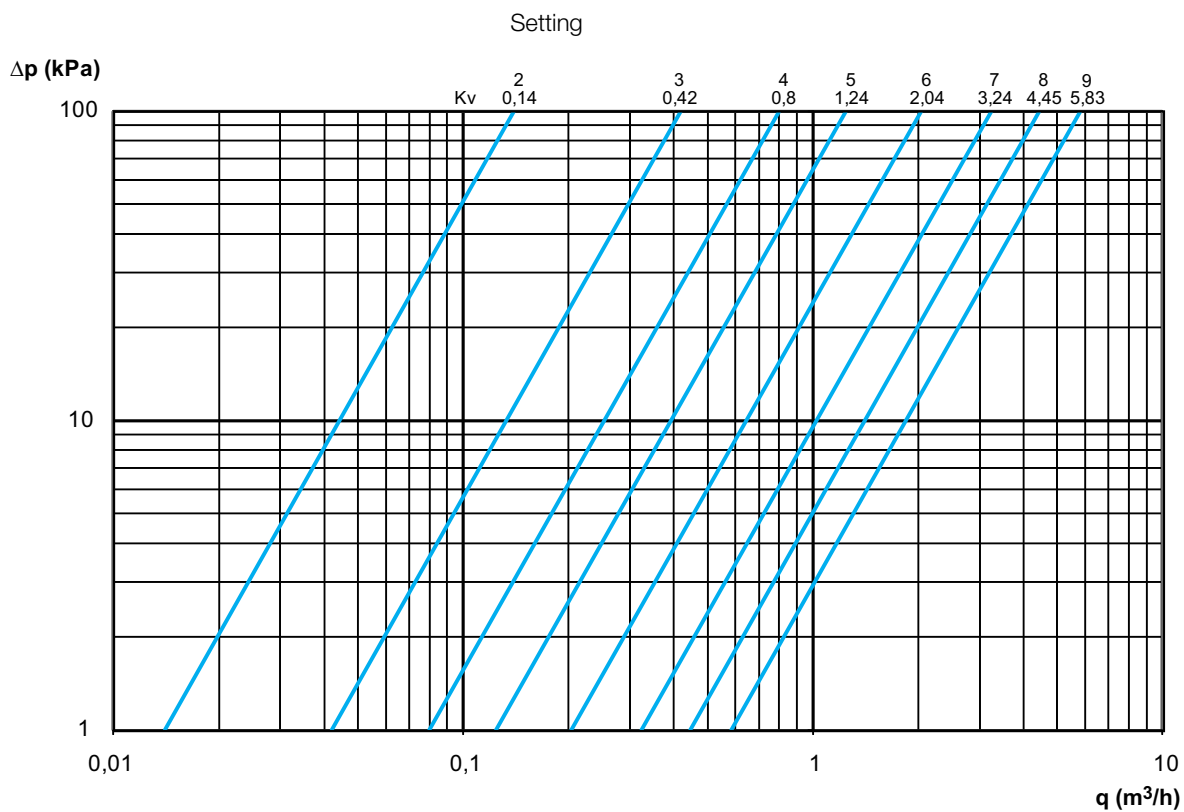

Diagram DN 25

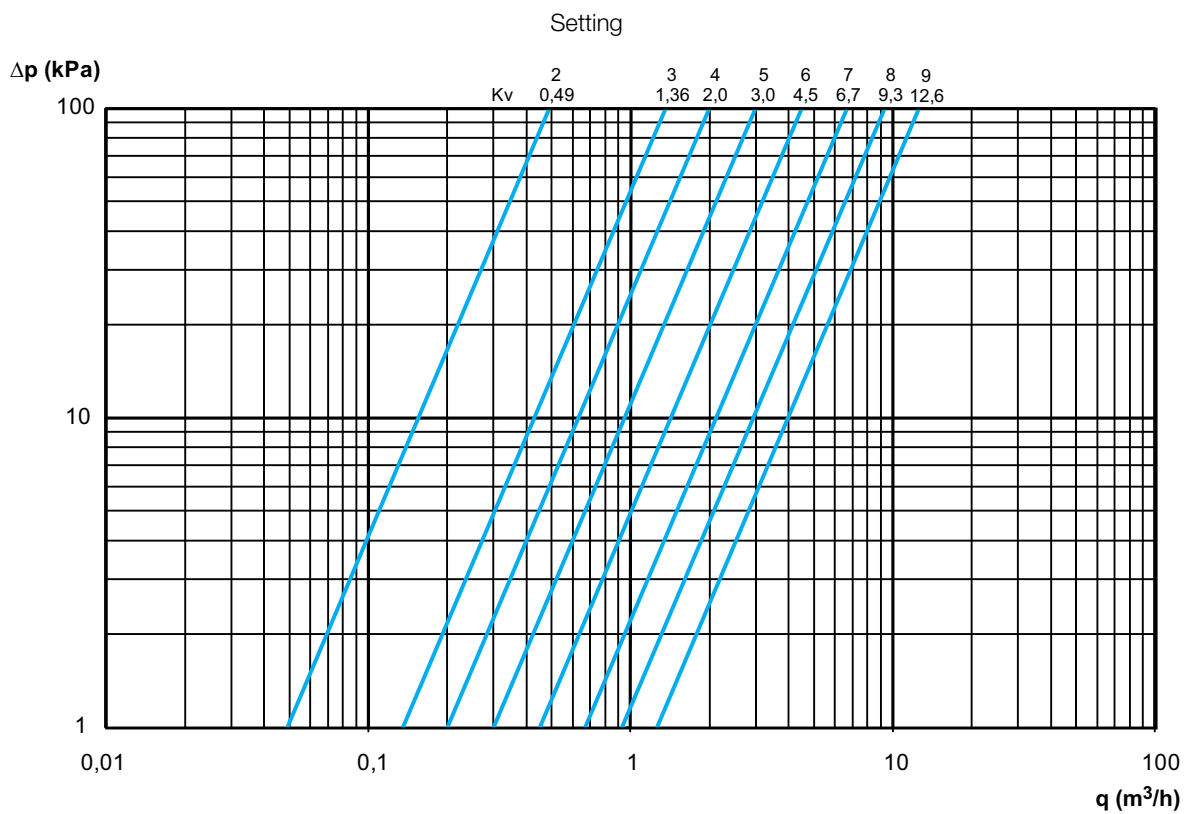

Diagram DN 32

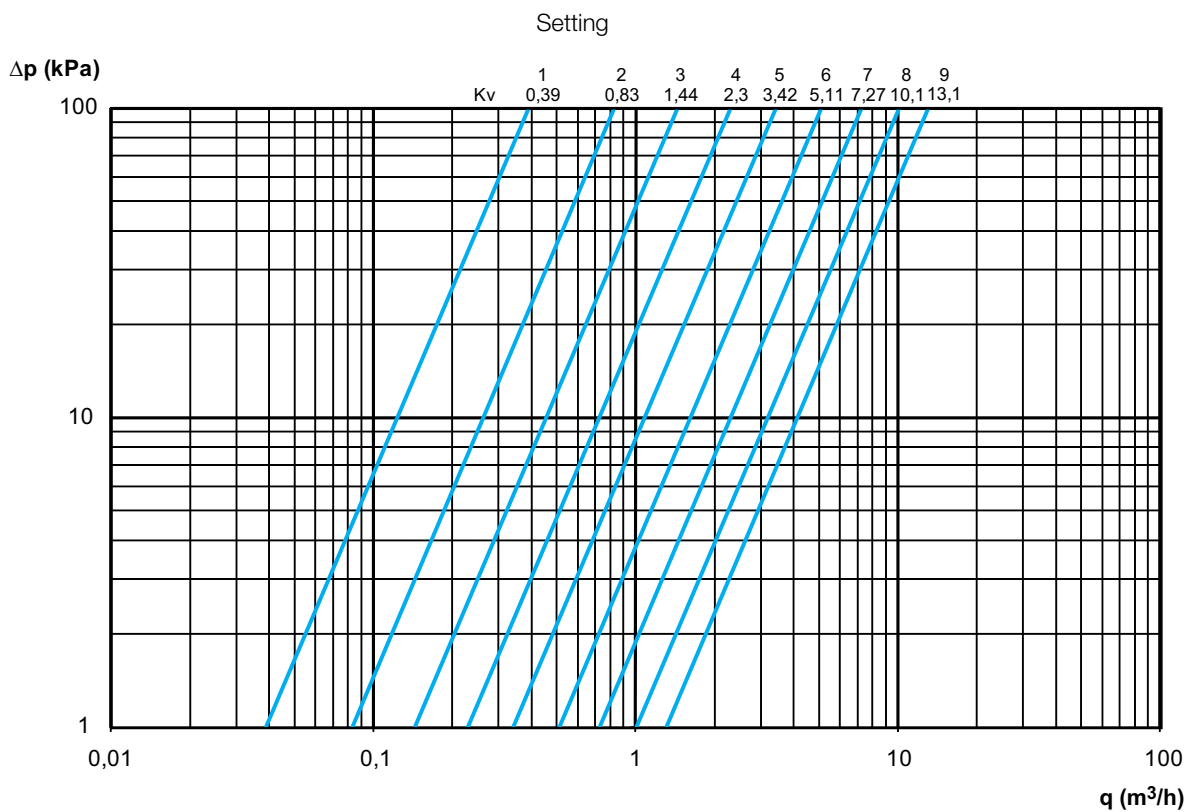

Diagram DN 40

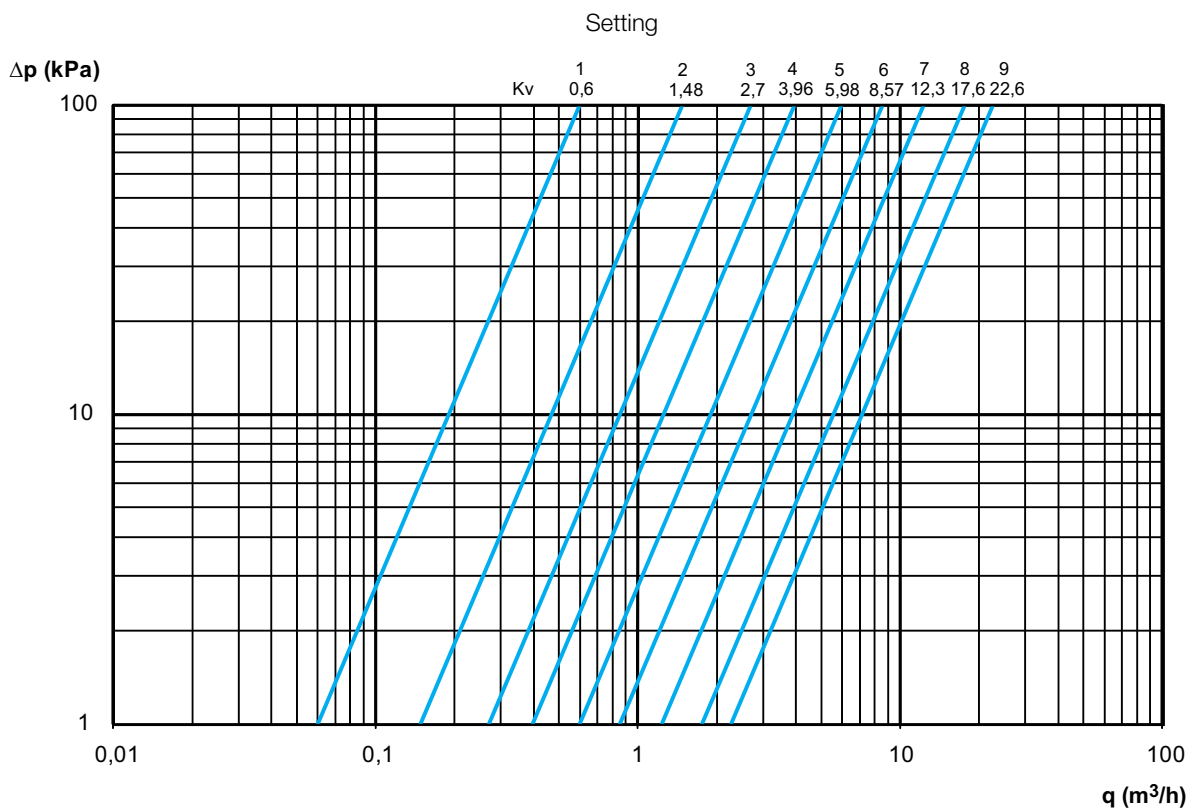

Diagram DN 50

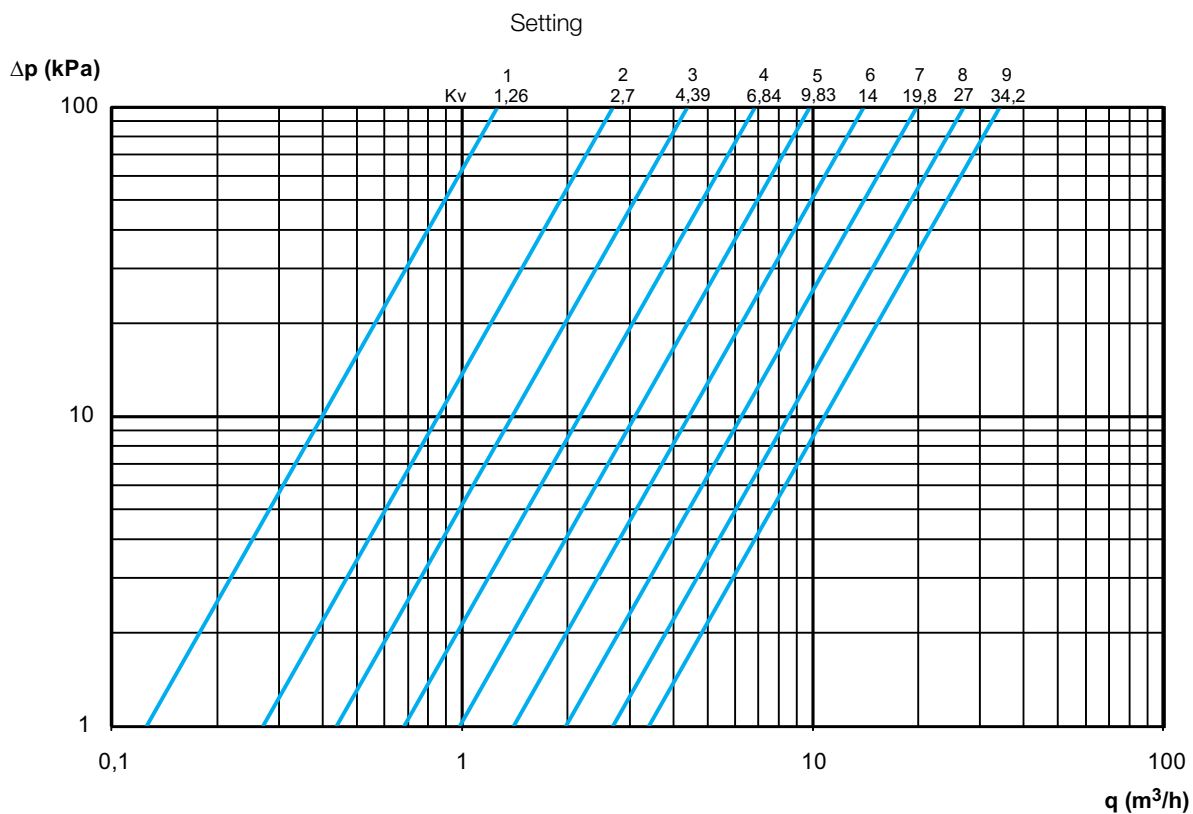

Diagram DN 65

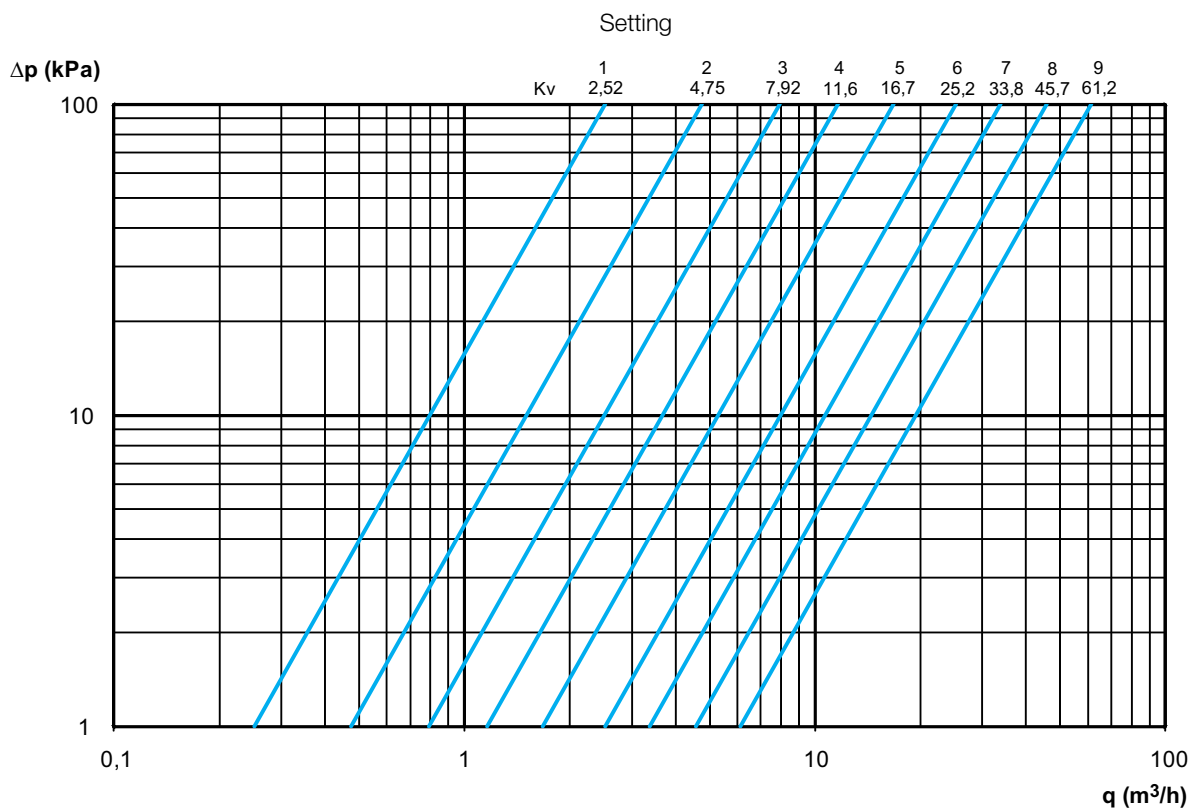

Diagram DN 80

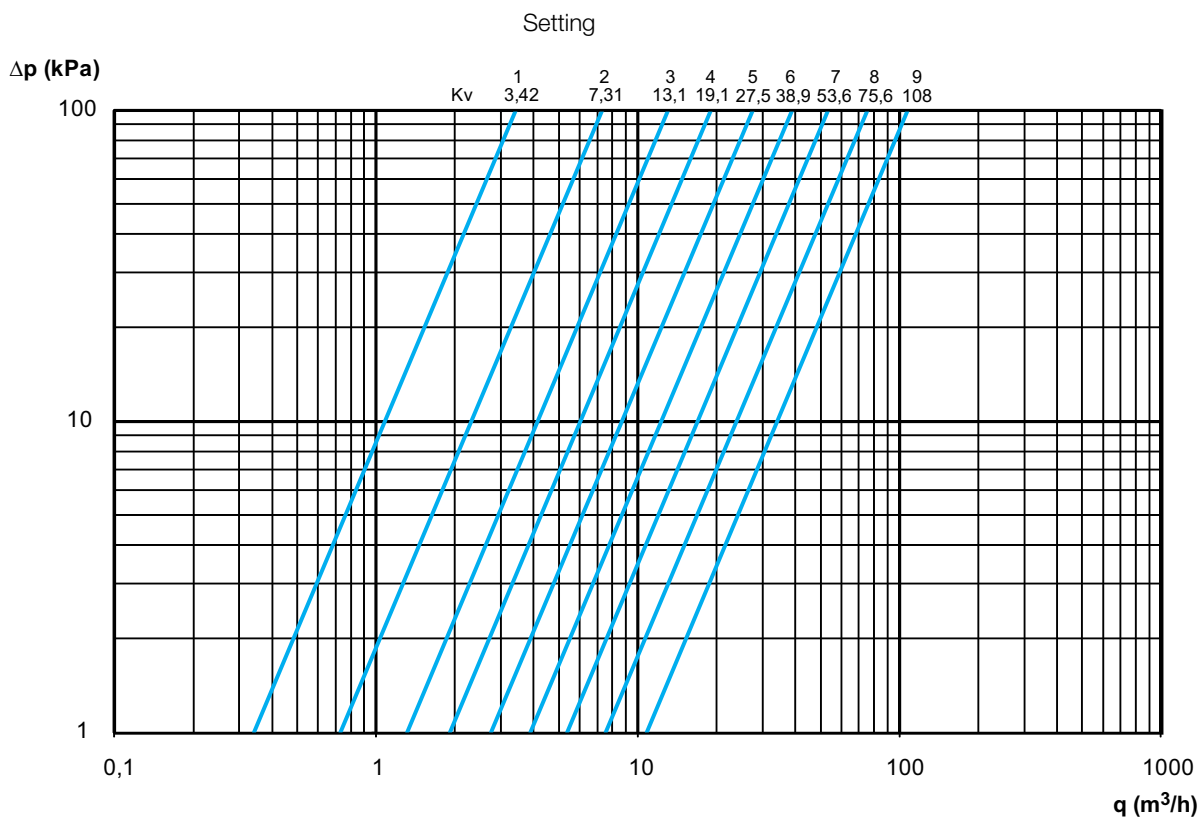

Diagram DN 100

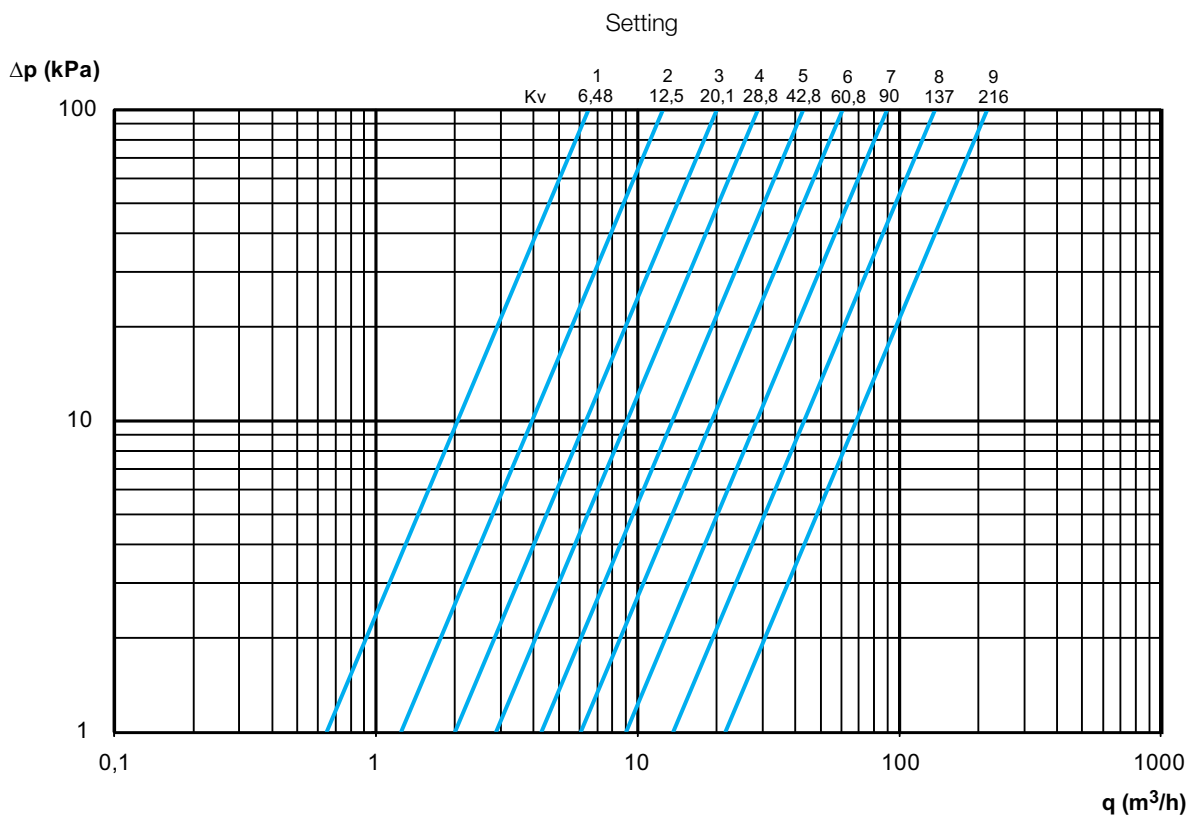

Diagram DN 125

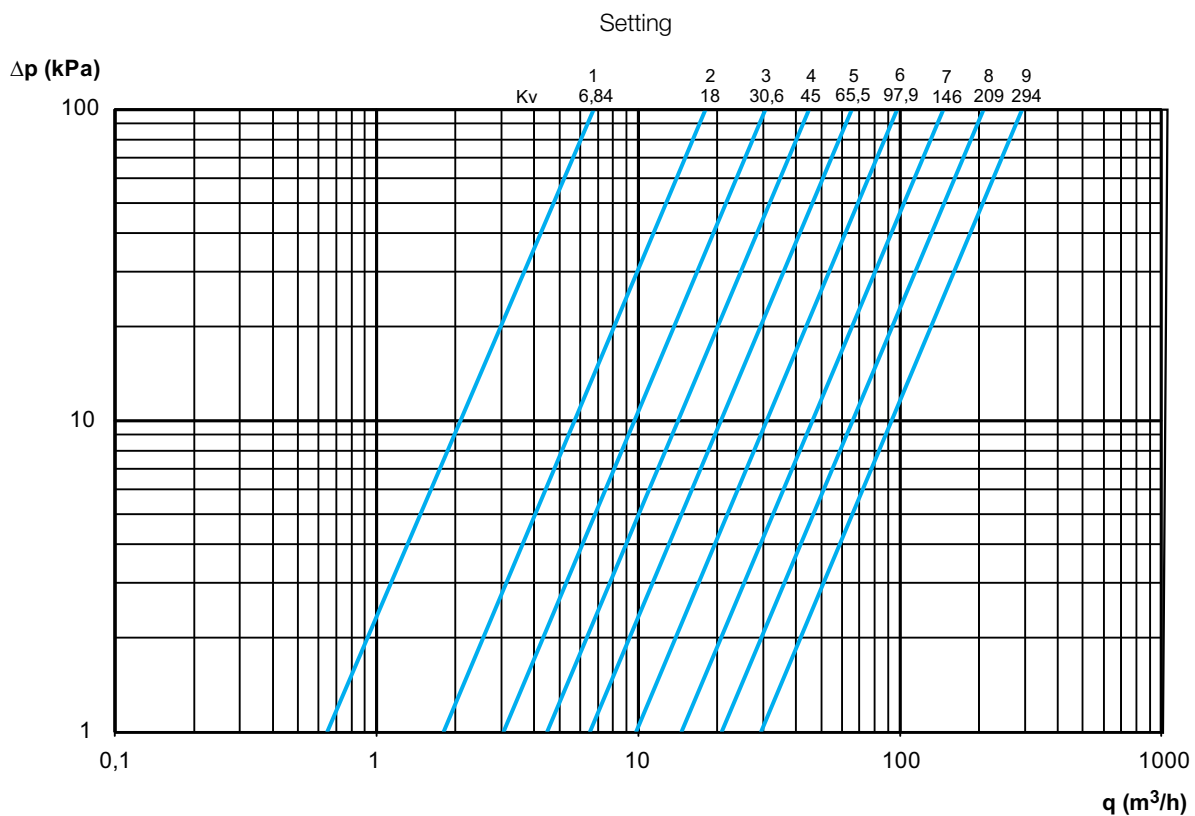

Diagram DN 150

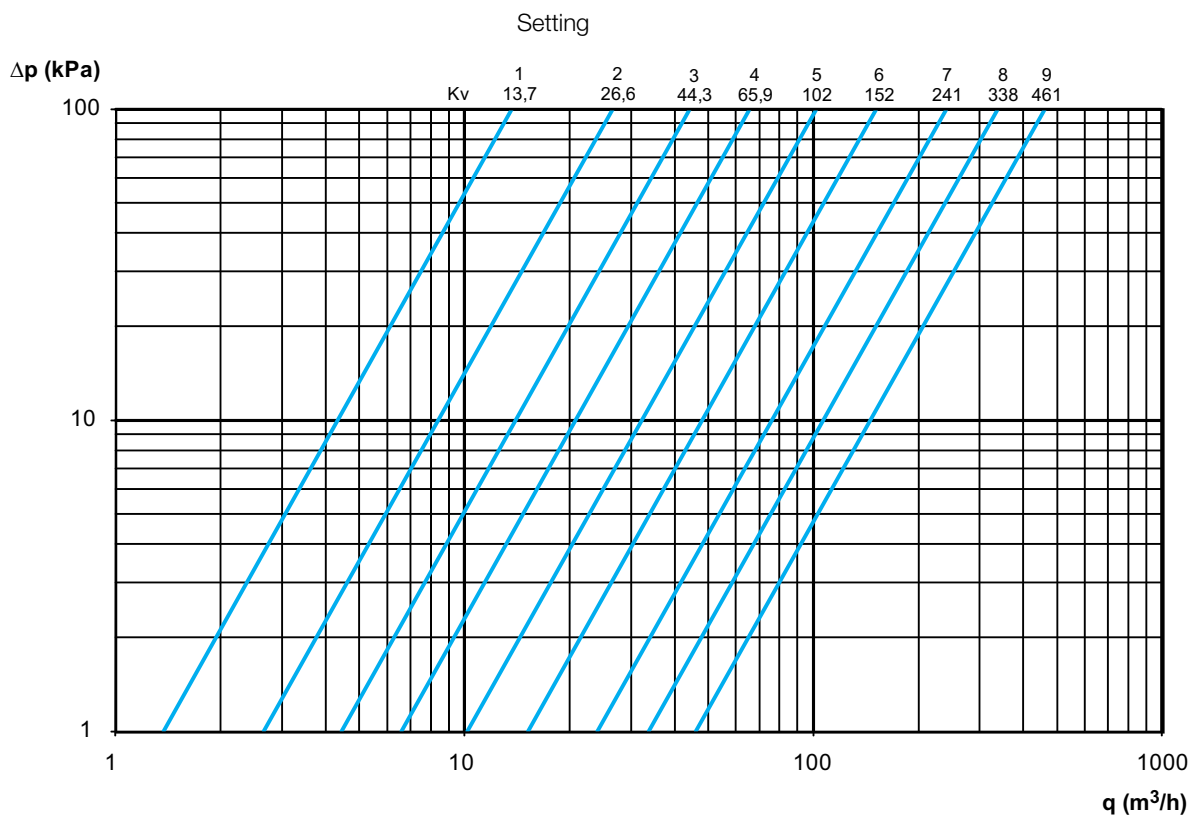

Diagram DN 200

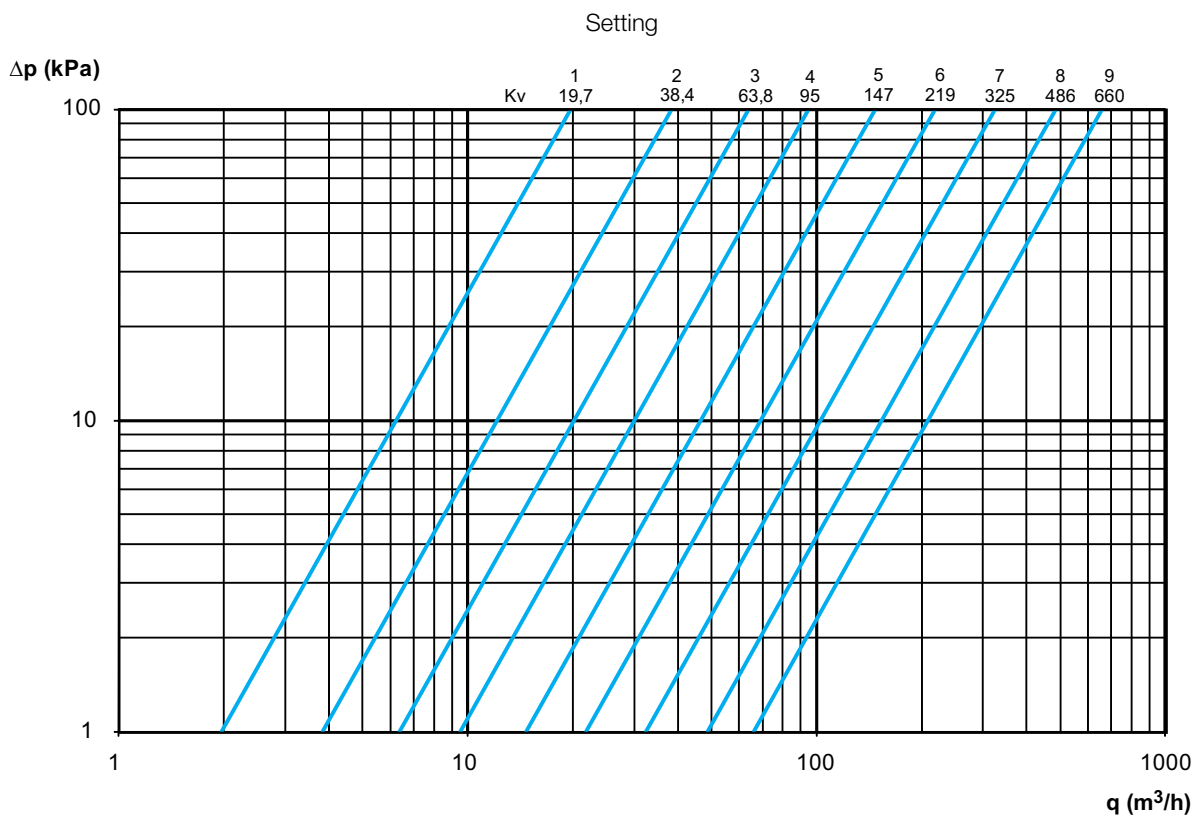
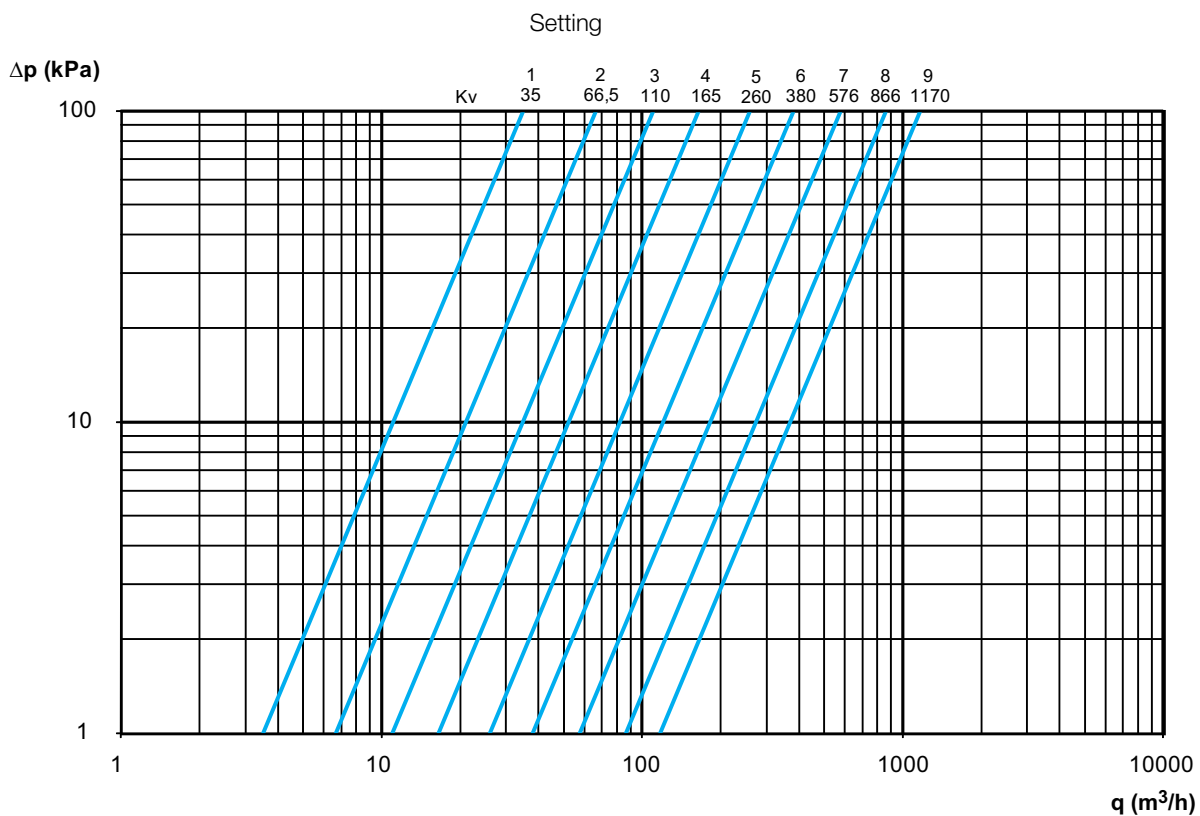
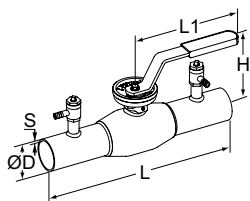

Diagram DN 250



TA-BVS 240 – Welding ends



Welding ends

DN	D	L	L1	H	S	Kvs	Kg	EAN	Article No
PN 40									
15	21,3	230	145	105	2	5,83	0,9	6415840183815	6-52 240-015
20	26,9	230	145	105	2	5,83	0,9	6415840183822	6-52 240-020
25	33,7	230	145	113	2	12,6	1,1	6415840183839	6-52 240-025
32	42,4	260	145	117	2	13,1	1,3	6415840183846	6-52 240-032
40	48,3	260	188	114	2,5	22,6	2,3	6415840183853	6-52 240-040
50	60,3	300	188	121	2,6	34,2	3,1	6415840183860	6-52 240-050
PN 25									
65	76,1	300	280	154	3	61,2	4,4	6415840183877	6-52 240-065
80	88,9	300	280	166	3	108	5,4	6415840183884	6-52 240-080
100	114,3	325	280	173	3	216	7,7	6415840183891	6-52 240-090
125	139,7	325	400	221	4	294	15,5	6415840183907	6-52 240-091
150	168,3	350	600	240	4	461	16,1	6415840183914	6-52 240-092
200*	219,1	400	-	-	4	660	38,2	6415840183921	6-52 240-093
250*	273,0	530	-	-	4	1170	73,6	6415840183938	6-52 240-094

*) Equipped with manual gear.

Kvs = m³/h at a pressure drop of 1 bar and fully open valve.

TA-BVS 243 – Flanged

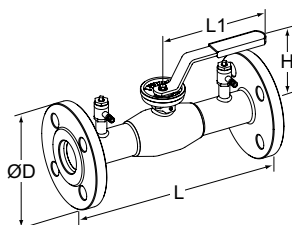

Flanged

DN	Number of bolt holes	D	L	L1	H	Kvs	Kg	EAN	Article No
PN 40									
15	4x14	95	250	145	105	5,83	2,1	6415840116813	6-52 243-015
20	4x14	105	250	145	105	5,83	2,6	6415840116820	6-52 243-020
25	4x14	115	240	145	113	12,6	3,1	6415840116837	6-52 243-025
32	4x18	140	280	145	117	13,1	4,7	6415840116844	6-52 243-032
40	4x18	150	270	188	114	22,6	6,0	6415840116851	6-52 243-040
50	4x18	165	310	188	121	34,2	8,1	6415840116868	6-52 243-050
PN 16									
65	8x18	185	310	280	160	61,2	10,1	6415840116875	6-52 243-065
80	8x18	200	310	280	173	108	12,0	6415840116882	6-52 243-080
100	8x18	220	350	280	173	216	15,9	6415840116899	6-52 243-090
125	8x18	250	355	400	221	294	25,6	6415840116905	6-52 243-091
150	8x22	285	370	600	240	461	30,0	6415840116912	6-52 243-092
200*	12x22	340	425	-	-	660	56,7	6415840116929	6-52 243-093
250*	12x26	405	550	-	-	1170	104	6415840116936	6-52 243-094

*) Equipped with manual gear.

Kvs = m³/h at a pressure drop of 1 bar and fully open valve.

